

# Twinkler RS232 Interface User Guide & Reference

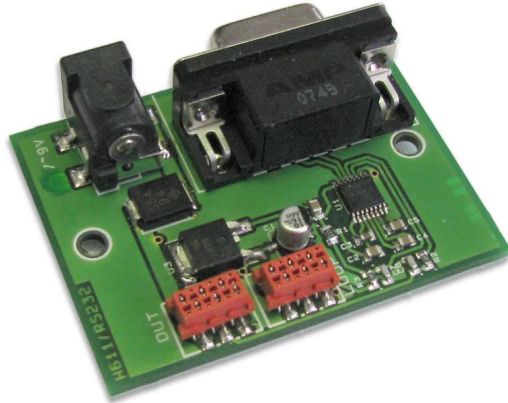

The RS232 interface for the “Twinkler” allows to configure and control a chain of Twinklers from a computer or other device, through a RS232 port. The interface can power a chain of up to 75 Twinklers, and it can control a chain of arbitrary length when power repeaters are added after every multiple of 75 Twinklers.

ITB CompuPhase  
Eerste Industriestraat 19-21  
1401 VL Bussum, The Netherlands

Tel.: +31 (0)35 6939261  
Fax.: +31 (0)35 6939293  
[info@compuphase.com](mailto:info@compuphase.com)  
[www.compuphase.com](http://www.compuphase.com)



2012-10-30

# Contents

Preliminary.....	2
Anti-static handling precautions.....	2
Legal disclaimer.....	2
Overview.....	3
Power connector.....	3
USB connector.....	3
Output and loop-back connectors.....	3
External I/O.....	4
Daisy-chaining Twinklers.....	4
Adding power repeaters.....	5
Twinkler software.....	6
Installing and configuring the software.....	6
Specifications.....	7
Absolute maximum ratings.....	7
Electrical.....	7
Operating conditions.....	7
Mechanical.....	7
Conformity.....	7
Accessories.....	7

## Preliminary

### *Anti-static handling precautions*

Please observe anti-static handling precautions when handling the device, as it contains components that are sensitive to static discharges.

### *Legal disclaimer*

ITB CompuPhase shall not be liable for the incidental or consequential losses or damage to tangible property, injury or death of a person in connection with the use of this device.

# Overview

The RS232 interface has 4 connectors, for power, RS232, Twinkler bus output and Twinkler bus loop-back.

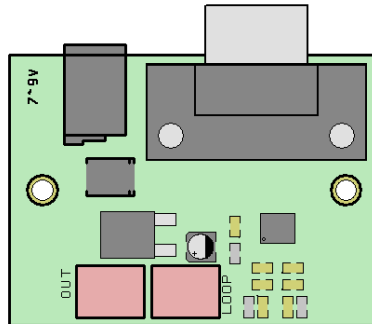

The Twinkler RS232 interface

## *Power connector*

The device must be externally powered. The DC power connector accepts a voltage between 6 V and 10 V; the recommended power voltage is between 7 V and 9 V.

The power connector is a standard low voltage power connector with a pin size of 2.1 mm. The pin is the plus pole.

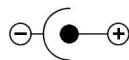

The required current of the power supply depends on the number of Twinklers being powered through the interface. The interface can handle a maximum current of 4 A.

## *RS232 connector*

The RS232 connector is a female 9-pin “D-subminiature” connector. Use a straight RS232 cable to connect the interface to a computer (not a “null-modem” cable). The RS232 interface functions as a DCE, if the device controlling the Twinkler chain is also configured as a DCE, you need a null-modem cable between that device and the RS232 interface (note: a computer is a DTE).

## *Output and loop-back connectors*

The Micro-MaTch connector of the interface (marked “OUTPUT”) must be attached to the “INPUT” connector on the Twinkler (see the above figure and the figure on the next page). The second Micro-MaTch connector on the interface board, labelled “LOOP”, is optionally connected —see the section “Daisy-chaining Twinklers” on page 4 for details.

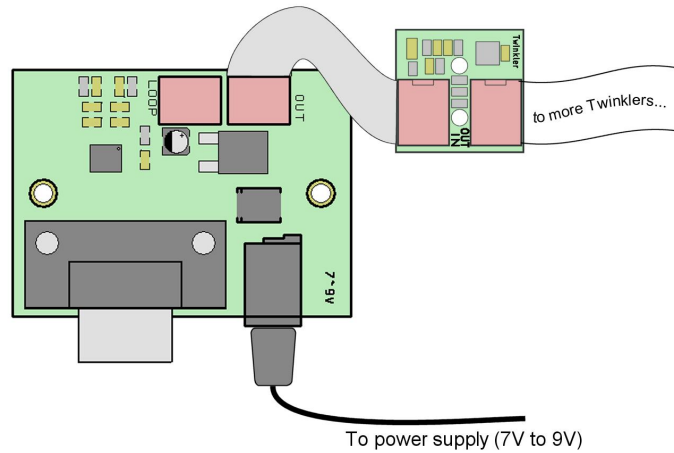

## *Daisy-chaining Twinklers*

Each Twinkler board has two connectors: one is input and the other is output. Both connectors are “Micro-MaTch” connectors for 6-wire ribbon cable (see Accessories on page 7). The connectors have a polarity notch for proper orientation. Daisy-chaining boards is a simple matter of connecting the “OUTPUT” of one board to the “INPUT” of the next board.

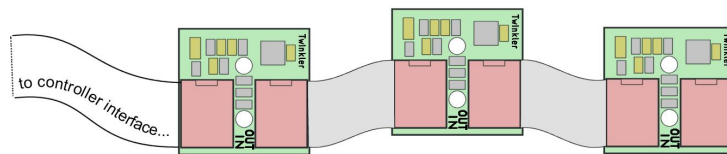

Optionally, you may also connect the “OUTPUT” of the last Twinkler board to the “LOOP” connector of the RS232 interface, thus creating a loop. A loop allows some basic diagnostics.

## *Adding power repeaters*

The maximum current consumption of each Twinkler board is specified at 45 mA. The ribbon cables and the connectors are specified at a maximum of 3.5 A at 20 °C. This means that a power line in a daisy-chain should be no longer than roughly 75 Twinklers. When chaining more than 75 Twinklers, a power repeater should be placed in the chain.

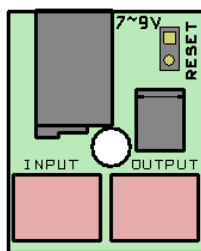

See also section Accessories on page 7.

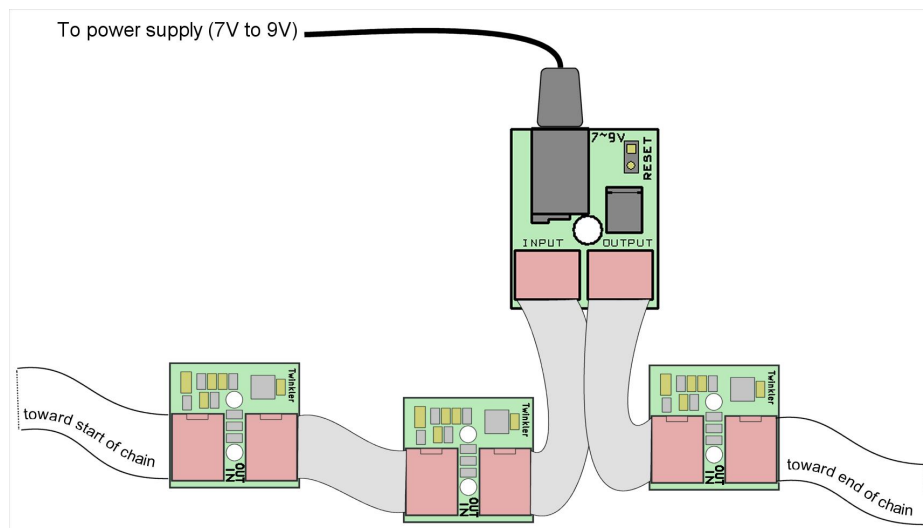

## Twinkler software

The software for the Twinkler exists for Microsoft Windows and for Linux, and is available as a free download from the CompuPhase web site. For Microsoft Windows, use the “setup” program to install it. For Linux, you can either use the self-installing “package” file, or install the program yourself by copying the executable file to the hard disk of your PC.

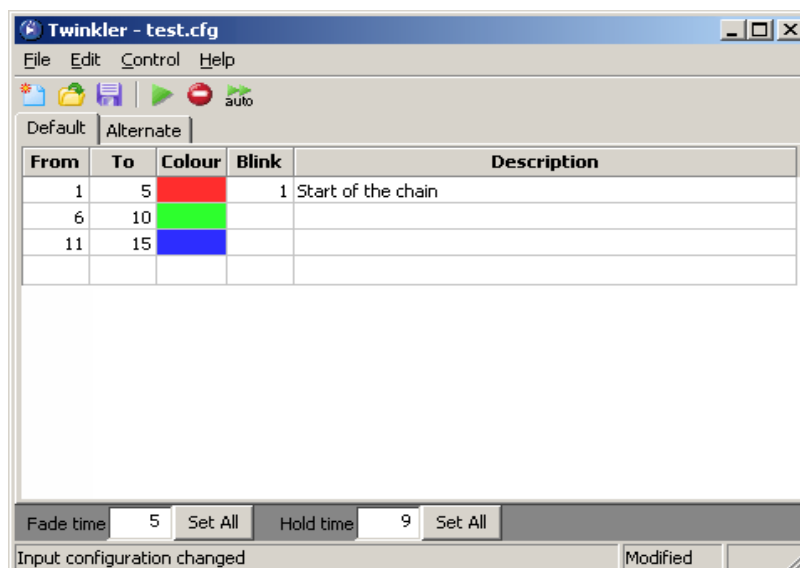

The Twinkler configuration utility (Microsoft Windows version)

After installation, run the program, and adjust the settings (menu “Tools”, then “Settings”). You should select a communication port for the program to use. For Microsoft Windows, the (virtual) COM ports are called “COM1”, “COM2”, etc. In Linux, standard serial ports are called “ttyS0”, “ttyS1”, etc. and USB virtual serial ports are called “ttyUSB0”, “ttyUSB1”, etc.

More information on configuring and using the standard software is in the User Guide for the Twinkler product. For making your own software, please refer to the application note "Programming the Twinklers" on the CompuPhase web site.

# Specifications

## *Absolute maximum ratings*

Operating voltage (Vcc)... -0.3 V to +10 V  
Input voltage on I/O pins. -0.5 V to 5.5 V  
Input current..... 5 A

## *Electrical*

Operating voltage (Vcc)... 6 V to 9 V DC.  
Current consumption..... 15 mA (typical).  
Serial line..... 5 V TTL logic levels, 9600 and 115200 bps.

## *Operating conditions*

Operating temperature.... -40 °C to +85 °C .  
Humidity..... 5% to 90% non-condensing.  
Vibration..... solid-state device, no moving parts.

## *Mechanical*

Board size..... 55 mm × 40 mm.  
Weight..... 0.02 kg.  
Mounting..... two holes, Ø3.2 mm; an enclosure with flanges is optionally available.

## *Conformity*

European Community..... EN 55022 (emission), EN 55024 (immunity).  
U.S.A..... t.b.a.  
RoHS..... Compliant with EU Directive 2002/95/EC.

## *Accessories*

Aluminium enclosure..... Enclosure with flanges, 64 mm × 40 mm × 30 mm  
Daisy-chain cables..... 6-wire ribbon cable, 1.27 mm pitch, AWG28; current capacity: 3.5 A for Vcc and ground wires at an ambient temperature of 20 °C.  
Twinkler..... Twinkler LED controller (with RGB LED and provision for a light pipe).  
Power distribution board. Passive board with two Micro-MaTch connectors and a DC power connector.  
Power supply..... Switching power supply, 7.5 V, 4 A (Mean Well P40A), with 2.1x5.5 DC plug; input voltage 90V~264 V AC.